

Winnox Burners

Model WX300 version 1.00

Main Specifications

PARAMETER		SPECIFICATIONS	
Blower Type		Packaged blower	Remote blower
Maximum input, BTU/hr (kW)  Note: <i>Capacities given without air filter.</i> <i>Contact factory for chamber pressures outside the given range, or varying chamber pressure conditions.</i>	Chamber pressure "WC (mbar)	Nominal (50 Hz and 60 Hz)	Pressure at air inlet 1 psig (70 mbar)
	-5.0 (-12.5)	3,360,000 (980)	4,080,000 (1200)
	-3.0 (-7.5)	3,220,000 (940)	3,910,000 (1150)
	0.0	3,000,000 (880)	3,630,000 (1060)
	1.0 (2.5)	2,930,000 (860)	3,540,000 (1040)
	2.0 (5.0)	2,850,000 (830)	3,430,000 (1010)
Minimum input, BTU/hr (kW)		200,000 (60)	
Fuel inlet pressure at ratio regulator, psi (mbar) ¹⁾	Maximum Minimum	2.0 (140) 1.0 (70)	3.0 (210) 2.0 (140)
Maximum chamber temperature, °F (°C)		Standard combustion tube: 1000 (540) High temp. combustion tube: 1600 (875) Block & Holder: 1800 (982)	
Flame Length	Alloy Tube Block & Holder	Flame is inside tube at all inputs Flame extends 10" (250mm) past outlet	
Excess Air, % at high fire		50%	
Piping		N.P.T. or B.S.P. burner piping available	
Flame detection		Flame Rod or U.V. Scanner	
Fuels		Natural gas, propane, butane ²⁾ <i>For any other mixed gas, contact Eclipse Combustion</i>	
Weight, lbs (kg)	Alloy Tube Block & Holder	296 (135) 551 (251)	173 (79) 428 (190)

- 1) For proper performance, this pressure must be kept constant across the burner operating range.
2) See Design Guide for more information about typical fuel composition and properties.

- All information is based on laboratory testing. Different chamber size and conditions will affect data.
- Maximum inputs for packaged blower versions are given for the standard combustion air blower without an inlet air filter.
- All inputs are based on gross calorific values and standard conditions: one atmosphere, 70° F (21° C)
- Eclipse reserves the right to change the construction and/or configuration of our products at any time without being obliged to adjust earlier supplies accordingly.



Eclipse Combustion

ISO 9001 Registered

Performance Graphs
WX300 v1.00

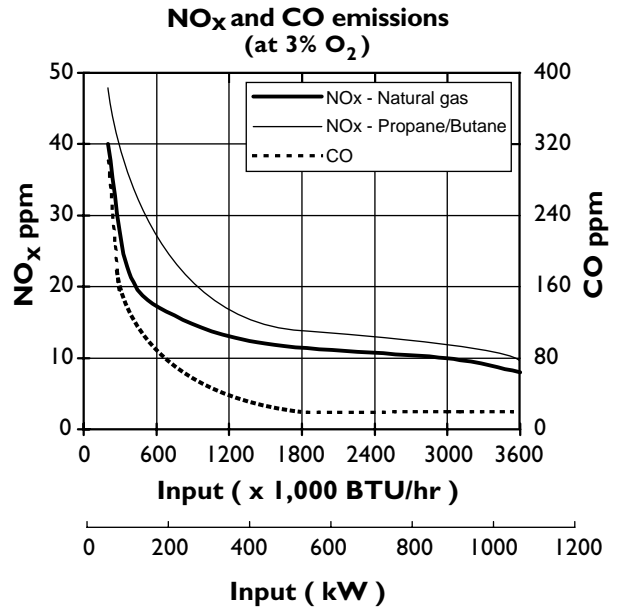
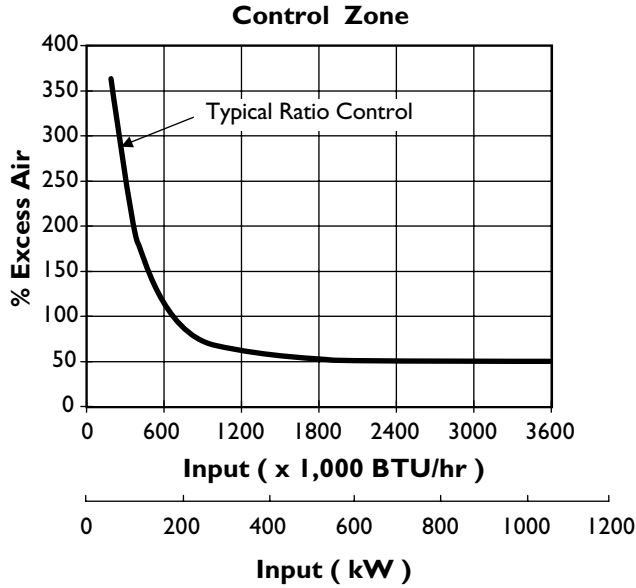

Input at low fire changes with ratio regulator adjustment.

Secondary by-pass fuel setting:

FUEL	ΔP "w.c. (mbar)*
Nat. Gas	4.5 (11.3)
Propane	1.5 (3.8)
Butane	2.5 (6.3)

* Measured between Tap "E" and the chamber @ low fire.

NO_x and CO emission data is given for:

- Ambient combustion air (~70 °F, 20 °C)
- Less than 1000 °F (540 °C) firing chamber
- Minimal process air velocity
- Low fire input adjusted to 340,000 BTU/hr (100kW)
- Neutral chamber pressure

Emissions are influenced by:

- Chamber conditions
- Fuel type
- Firing rate
- Ratio regulator adjustments
- Combustion air temperature

CO emission is largely influenced by chamber conditions. Contact your local Eclipse Combustion representative for an estimate of CO emission on your application.

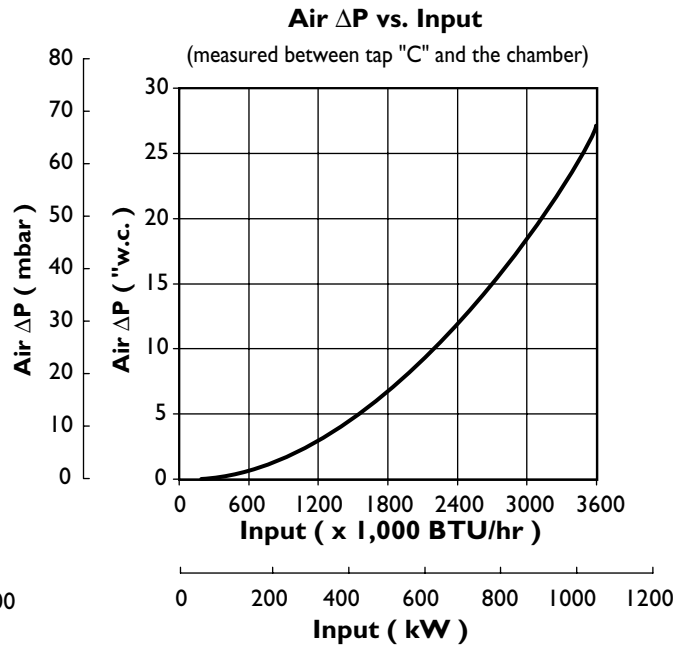
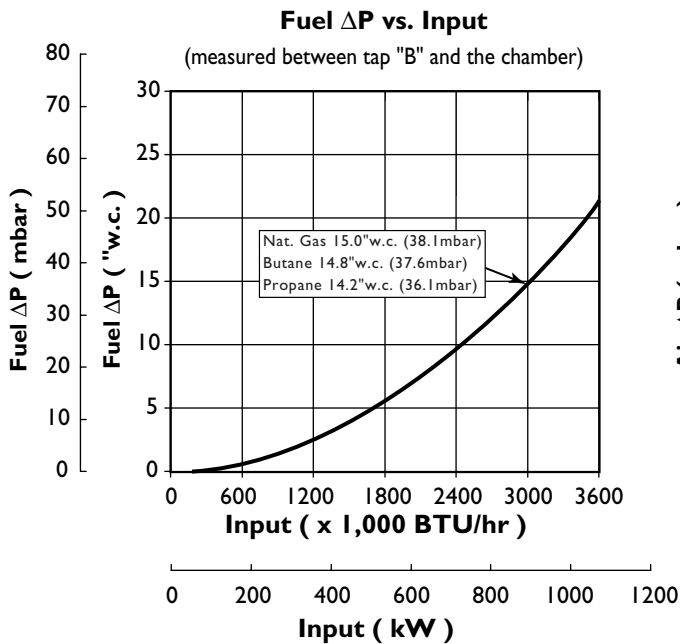

Dimensions
WX300 v1.00

Dimensions in mm (in)

Packaged blower

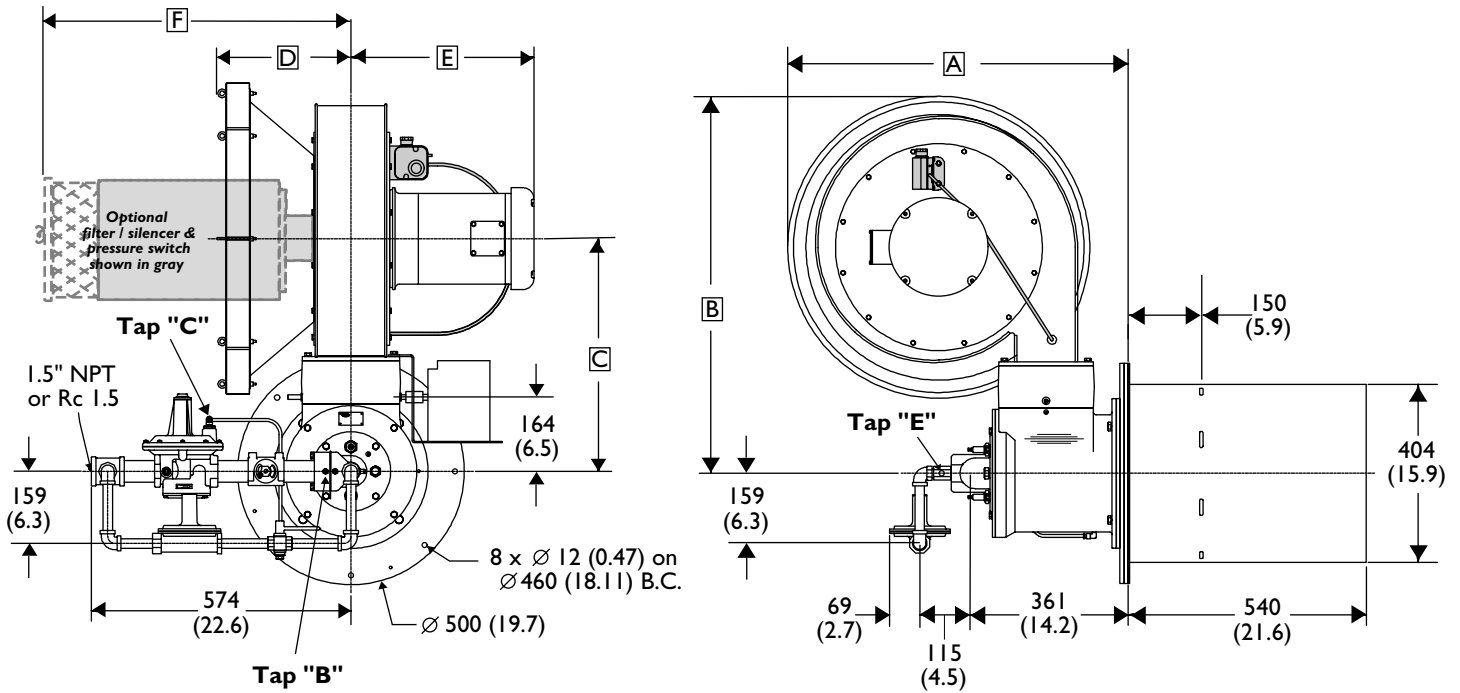

		Blower Type	
		60 Hz	50 Hz
Dimensions	A	774 (30.47)	806 (31.73)
	B	856 (33.70)	906 (35.67)
	C	514 (20.24)	564 (22.20)
	D	294 (11.57)	294 (11.57)
	E	404 (15.91)	450 (17.72)
	F	997 (39.25)	997 (39.25)

Block & Holder

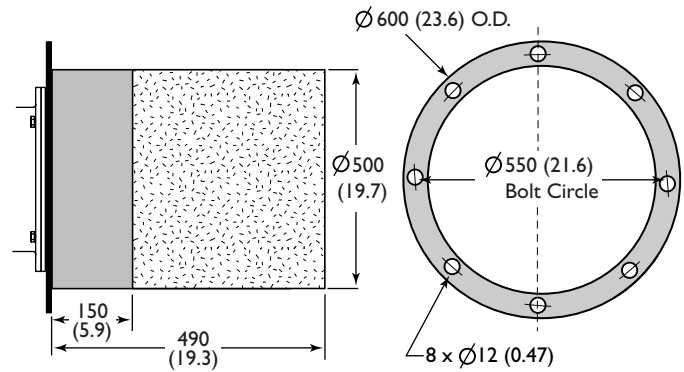

Remote blower

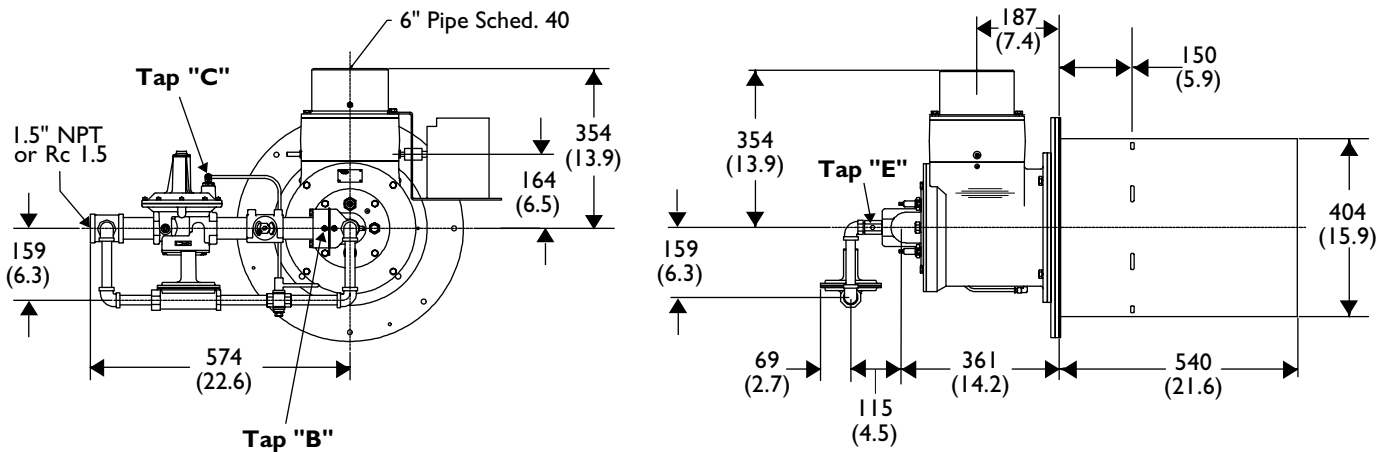



Eclipse Combustion

Offered By:

Power Equipment Company
2011 Williamsburg Road
Richmond, VA 23231
Phone: 804-236-3800 Fax: 804-236-3882

www.peconet.com